

Bike carriers for van

In the various series of bike carriers, the following models are available for installation on vans.

maximum loading capacity: 50kg

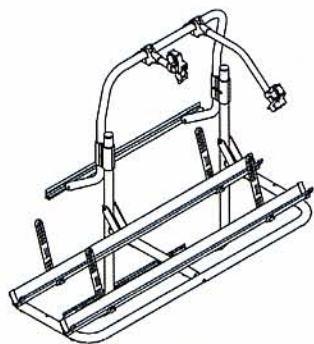

art.nr. 18523200

OMNI-BIKE plus for DUCATO-JUMPER-BOXER

This carrier with the installation rail is mounted on the rear door of a Fiat Ducato. The door can be opened without removing the bikes; the bike carrier rails are positioned towards the extreme left hand side in order that the width of the bikes does not exceed the width of the vehicle! The bike rack for Ducato can only be mounted with the installation profiles.



art.nr. 18054000

maximum loading capacity: 50kg

OMNI-BIKE deluxe 2 DOORS

This bike rack is installed on the right-hand rear door but can also be adjusted for installation on the left-hand rear door (see photo). The door can be opened without removing the bikes. The rails are equipped with Quick-blockers ensuring the wheels are safely locked. The Quickblockers can be moved over a length of 125cm.

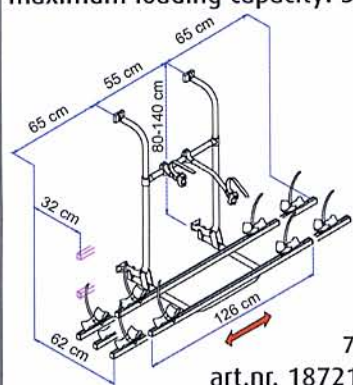

art.nr. 18721200



maximum loading capacity: 50kg

OMNI-BIKE plus TWIN

Advantage:
strong mounting due to
3 point fixing on each door.
Bikes have to be removed when
opening the door.

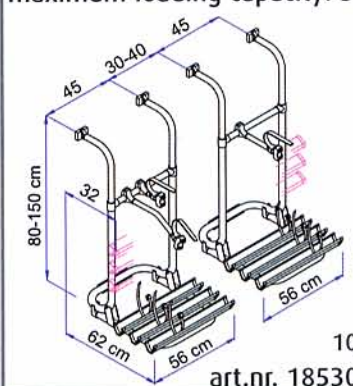

art.nr. 18530100

www.motorcaravanning.co.uk



maximum loading capacity: 50kg

OMNI-BIKE plus VW T4

Special frame with clamps by which the bike carrier is hung to the rear door. No drilling. Special supports for the back bumper included. Rear door can be opened with installed bike carrier.
Can be extended to a 3 or 4 bike carrier.

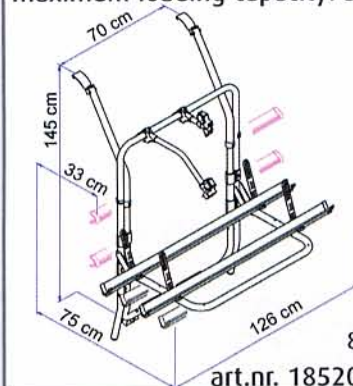

art.nr. 18520400

