

DC Airco 4400

Manual /Einbau /Manual/ Montage

12/24 Volt



MANUAL/EINBAU/MANUAL /MONTAGE

The box Contains the following items:

- 1 DC Airco 4400
- 1 bag of 4 screws and 4 bolts
- 1 bag of spare fuses on circuit board
- 1 Control panel
- 1 Instruction manual
- 1 Main Fuse Holder + fuse

Lieferumfang:

- 1 DC Airco 4400
- 1 Beipack 4 Bolzen und 4 Schrauben
- 1 Beipack mit Ersatzsicherungen (platine)
- 1 Bedienungspaneel
- 1 Bedienungsanleitung
- 1 Sicherunghalter + Sicherung

Bij geleverde onderdelen:

- 1 DC Airco 4400
- 1 Zakje met 4 schroeven en 4 bouten
- 1 Zakje met reserve zekering: printplaat
- 1 Bedieningspaneel
- 1 Montage handleiding
- 1 zekeringhouder + zekering

Le carton fourni doit contenir les uivantes:

- 1 DC Airco 4400
- 1 Sachet avec 4 vis et 4 boulons
- 1 Sachet avec des fusibles de rechange (platine)
- 1 Panneau de commande
- 1 Manuel d'utilisation
- 1 Fusible + porte fusibles

DC Airco 4400

Manual /Einbau /Manual/ Montage

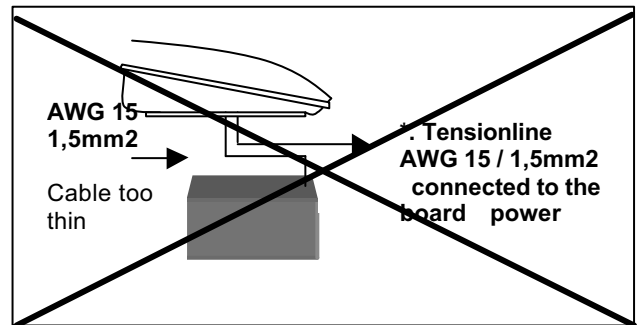
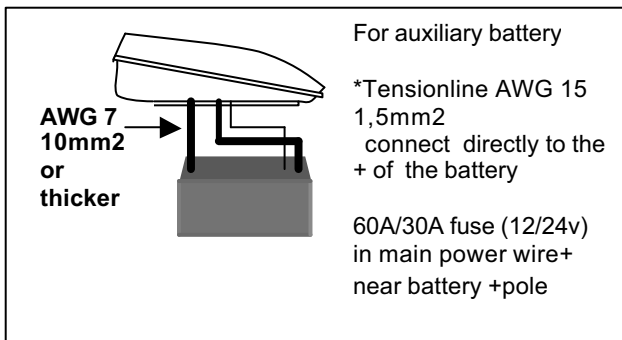
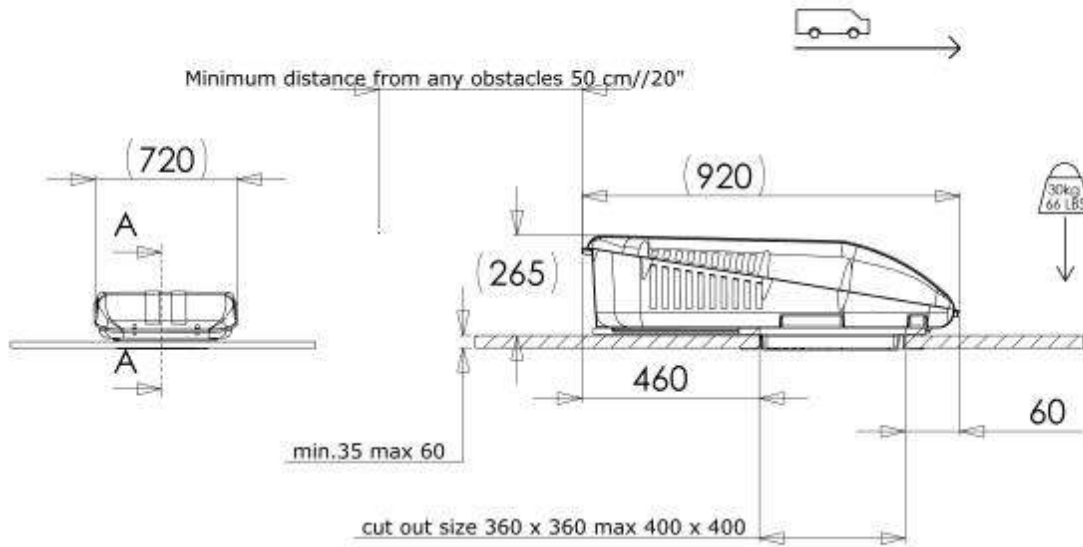

Attention

12 volt

- 1xAWG 7 / 10mm² black - battery
- 1xAWG 7 / 10mm² red + battery
- AWG 15 / 1,5mm² red + battery
- 24 volt use halve of cable thickness minimum

DC Airco 4400

Manual /Einbau /Manual/ Montage

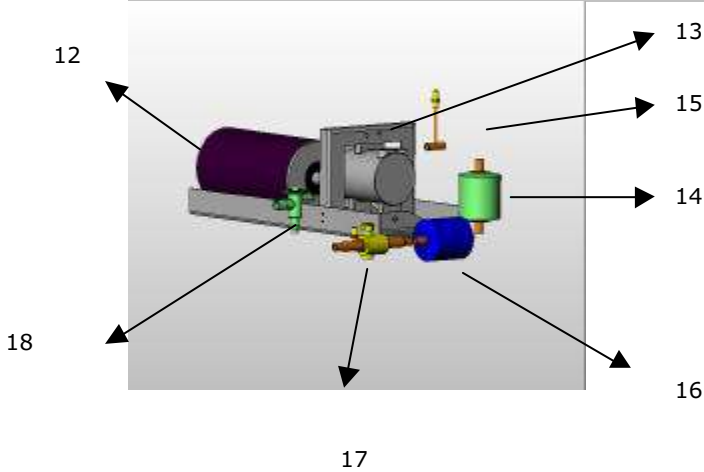
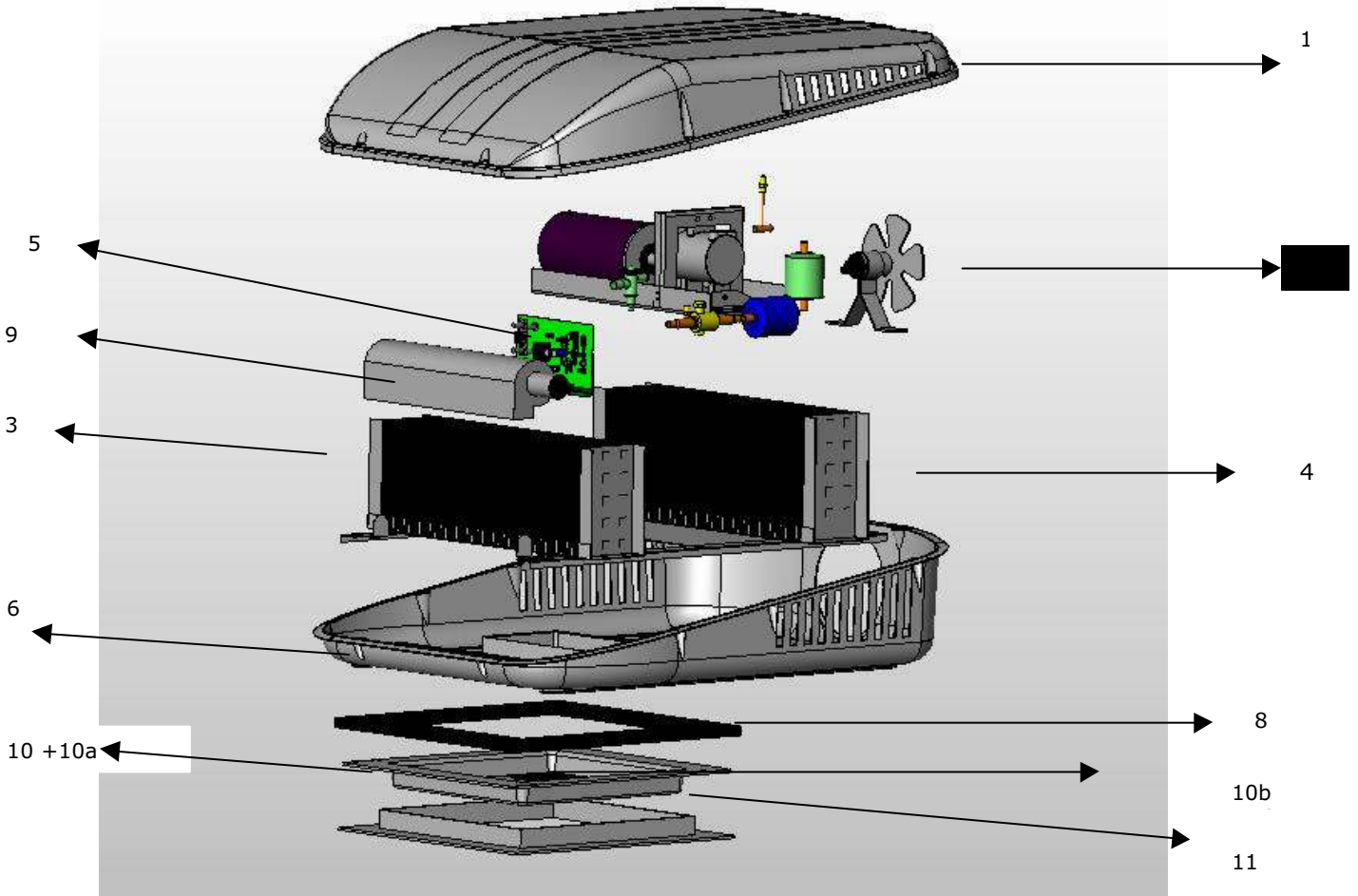

Description	part number
1 ABS cover -	dc4400RM/01
3 evaporator	dc4400RM/03
4 condenser	dc4400RM/04
5 circuit board 12 volt	dc 4400RM/05/12
circuit board 24 volt	dc 4400RM/05/24
6 ABS base	dc4400RM/06
7 rear fans 12 volt	dc4400RM/07/12
rear fans 24 volt	dc4400RM/07/24
8 rubber packing	dc4400RM/08
9 front fans 12 volt	dc4400RM/09/12
front fans 24 volt	dc4400RM/09/24
10 Air diffuser	dc4400RM/10
10a Switches	dc4400RM10a
10b Adjustable air grill	dc4400RM10b
11 thermostat	dc4400RM/11
12 electric motor 12 volt	dc4400RM/12/12
electric motor 24 volt	dc4400RM/12/24
13 compressor	dc4400RM/13
14 filter	dc4400RM/14
15 oil-fill nipple ¼	dc4400RM/15
16 filter/dryer	dc4400RM/16
17 valve + fill nipple ¼	dc4400RM/17
18 thermic exp.valve	dc4400RM/18

DC Airco 4400

Manual /Einbau /Manual/ Montage

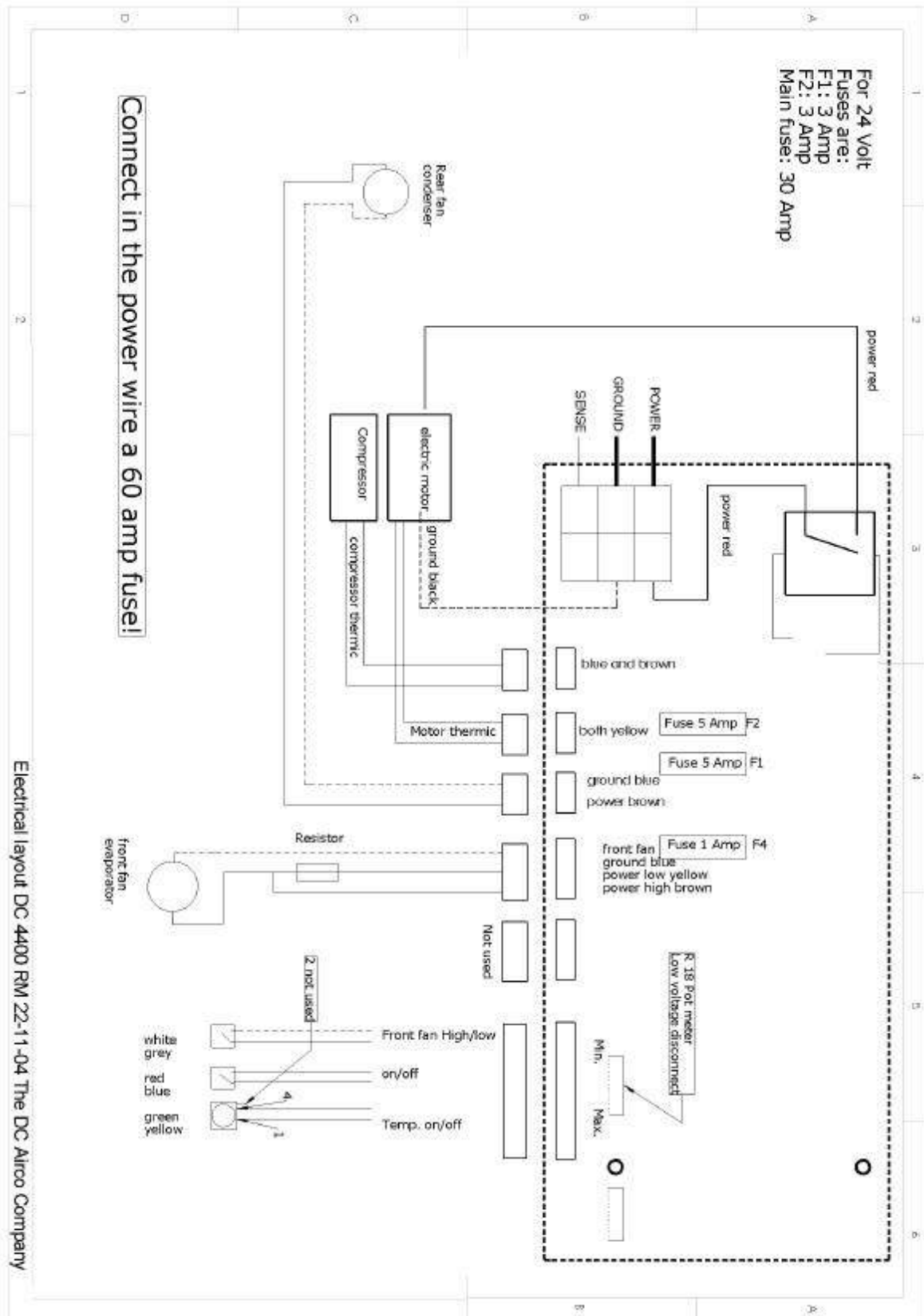

DC Airco 4400

Manual /Einbau /Manual/ Montage

Incorrect installation and/or misuse of the product can result in permanent damage and possible injury. To avoid this happening please read this instruction manual thoroughly.

The manual describes examples as they are found in installation and trouble shooting. We reserve the right to make changes without prior warning.

Congratulations, the purchase of the DC Airco is a wise choice. The main features of the DC Airco are, low power consumption, easy installation, quiet operation, the ability to operate while on the move and an environmentally friendly coolant (R134A).

The DC Airco is not designed for very vibrating/pushing vehicles such as not limited to : earth moving equipment, forklift trucks a.o.

1.2.3.4 Mounting plan

1

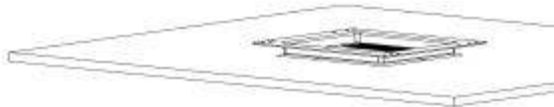

- Make (wooden) reinforcement around the hole (360x360mm/14,25x14,25inch) if the roof is not stable.
- Use soft staying kit between the roof and the grey grill, to prevent water leakage.
- Use the grey grill as a template to drill the 4 bolt holes.
- The black adjustable grill is facing to front of vehicle
- Lift the Airco with 2 men on the roof. Do not remove the cover.
- Remove plastic protection folio.

2

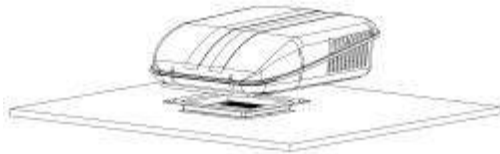

- Remove cover.
- Put bolt from inside through roof. Tighten the bolts by hand, not too fast to avoid cracking the plastic housing of the Airco.
- Connect fuse holder without the 60A/30A fuse in the main plus wire close to the battery.
- Connect the 3 wires direct to the battery poles

3



- Connect the 8 pole green connector of the grey air in/outlet grid with the circuit board.
- Mount the grey grid with the 4 screws against the roof.
- Place the main fuse 60A/30A in the fuse holder near the battery.

4

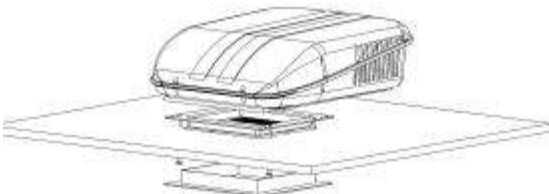

In case of working of repair always take the fuse out.

DC Airco 4400

Manual /Einbau /Manual/ Montage

3.1 Operation & Maintenance

With the DC Airco you have bought a normal operating air-conditioning system which is virtually maintenance free. However we would like to give some details that will guarantee trouble free operating.

3.2. Power consumption & battery capacity

The 4400 consumes 25 A/h maximum on 12 volts. (12,5A/24V) We advise therefore a battery capacity of no less than 250 Amp hours. On a camping site you can run it over the battery charger. Consumption 2A/230v, 4A/115v.

3.3. Energy saving

The DC Airco uses much less power than a conventional 230/115 volt mains air conditioner. But you can still make the power consumption lower by following these procedures.

- Overcome too much radiation of the sun. Less sun means a lower temperature inside and thus a lower energy consumption. Keep window and door blinds down and doors closed. Also keep the roof lights closed.
- If possible improve insulation of the vehicle. The DC Airco should be **the only air supplier** in the motor home.

3.4 Power supply information

When driving the alternator will keep the battery charged. The capacity of the alternator is however important. For the 4400 we advise an alternator of at least 60A/12V or 30A/24V . When you are camping for more days you need a 25A/12v (12,5A/24v) battery charger.

3.5. The control panel

- With the switch marked with a snowflake you can switch the Airco off/on.
- With the switch marked with a fan you can change the air speed inside the vehicle.
- With the timer switch the DC Airco can run for 2 hours.

3.6. Troubleshooting

3.6.1. Insufficient cooling

- Too much direct sunlight – pull down blinds – close doors – close roof light.
- Poor insulation.
- Too many people in the vehicle. Each person produces 200 Watts/1618BTU of body heat.
- The vehicle is too large.
- Check that outside rear fan is turning and not blocked by debris like leaves.

3.6.2. The DC Airco is not operating at all

- The fuse of the circuit board is blown (F4). Use the reserve fuse .(1A max.)
- The automatic battery protection cut in. This will automatically be reset when the battery tension is more than 12,6 volt. With 24 volts this happens at 25,2 volts. Two red LED's are burning if you look trough the air outlet grid.
- The main fuse near the battery is blown.
- With Gel batteries the potmeter R 18 on the circuit board needs to be turned to minimum (right).
- After mounting it might take 1-5 minutes before the Airco starts to cool.
- The main fuse near battery is blown

3.6.3. The DC Airco is switching on and off continuously

- The cables between the battery and the DC Airco are too thin. The red LED's in the Sunny/DC Airco are also switching on and off continuously.
- The battery is low. Perhaps the battery charger is not capable of giving a sufficient charge. Turn the airco off to allow the battery to be recharged.
- The tension wire is not connected straight to the battery plus pole.

3.6.4. The DC Airco is not cooling, while the ventilators are running

- The overheat fuse of the motor has tripped; the DC Airco will turn itself on after circa 10 minutes.
- The cooling agent is too less. The temperature difference between the air inlet grid and the air outlet grid must be 8°C/11°F, when the ventilators are in the „high“ position. If the temperature difference is significant less, get in touch with your supplier. The system is easy to refill by a refrigerant expert.



DC Airco 4400

Manual /Einbau /Manual/ Montage

3.6.5. The DC Airco is cooling, but is thumping intensively

- Check whether the rear fan is running. If this is not running the fuse (F2) of the rear fans is blown. Remove the cover and replace fuse. (reserve fuse present on the circuit board)

- In winter the Airco could make some noise, as the TEV is still blocking through the cold.

3.6.6. Water leakage

- Check that the condensation drainage holes are clear.

The Airco has a 12 month warranty taken the following conditions into account:

Guarantee card must be filled in completely with a copy of the invoice.

A description of the complaint must be added.

The serial number on the invoice must correspond to the serial number in the Airco. When the serial number has been removed the guarantee is automatically expired. You can find the serial number on you manual and under the Airco if you remove the inlet grid and the fan assembly.

DC Airco limited Warranty

DC AIRCO COMPANY warrants the DC AIRCO air conditioners to be free from defects in materials and workmanship under normal applications, use and services conditions for (1) year from date of delivery or (1,5) year after date of production whatever comes first.

Should any part prove defective within the warranty period, the customer may choose to return the defective product that is under warranty to The DC Airco Company or their representatives for repair at no charge or the customer has the option to repair the defective product at his own expense and The DC Airco Company or their representative will supply repair parts at no charge providing the defective part is returned or a photo sent though e-mail, and found to have failed under warranty. Parts supplied as warranty replacement parts will assume the balance of warranty on the part returned for warranty consideration.

What This Warranty Does Not Cover.

This warranty does not apply to any of the DC Airco's which have been subject to misuse, neglect or accident, or which have been damaged through abuse, alteration, improper installation, or negligence in use, prolonged operation with dirty filters, storage, transportation or handling, or which as been repaired/refilled with other refrigerant than R134A + PAG oil.

Warranty Limitations

There is no other expressed warranty on these products. The DC Airco Company and their representatives are not responsible for any incidental or consequential damages arising from the use or loss of use of the product. The DC Airco Company and their representatives maximum liability under any warranty, expressed, implied, or statutory, is limited to the purchasers price of the product. The purchasers exclusive remedy shall only be as stated herein.

DC Airco 4400

Manual /Einbau /Manual/ Montage

CHECKLIST DC AIRCO

Concerns the DC AIRCO 4400

: 12 volt
 24 volt

The Airco does not work at all. See also chapter 3.6.2.			
	Yes	Now	Action
Is the tension wire direct connected with battery plus pole.	<input type="radio"/>	<input type="radio"/>	Connect according the manual.
The Airco stops working See 3.6.2. and 3.6.3.			
If the Airco stops due to low battery voltage 2 red led's will illuminate on the circuit board.(look inside through air inlet up wards)	<input type="radio"/>	<input type="radio"/>	Battery voltage to low Start engine to test this.
By Gel batteries R18 turn to minimum .(right)	<input type="radio"/>	<input type="radio"/>	Look 3.6.2.
The Airco turn but does not cool down 3.6.4. and /or 3.6.5.			
Does the front fans turn.	<input type="radio"/>	<input type="radio"/>	Change fuse F1
Does the rear fan turn.	<input type="radio"/>	<input type="radio"/>	Change fuse F2
There is green oil in the airco	<input type="radio"/>	<input type="radio"/>	Contact service point
The Airco is working but is not cooling enough 3.6.1.			
Start the airco for 15 minutes with the cover closed removed screws already. Turn the Airco off and check if the front heat exchanger is cold for 3/4.	<input type="radio"/>	<input type="radio"/>	Short on refrigerant

Cable thickness of the +cable min AWG 7/10mm²
 Cable thickness of the -cable min AWG 7/10mm²
 Cable thickness of the tension cable min AWG15/1,5mm²

Battery capacity : min 250 Ah
 Battery changer : min 25Ah/12v 12,5Ah/24v

