



BACKPACK 4X4



**Ultra-versatile version for minivans.
Rapid installation to the rear spare tyre
thanks to sturdy straps**

It is necessary to remove the rigid cover of the spare tyre. Pay attention so it does not cover the lights and the number plate. Carries 2 bikes. Folding rail support base. Standard delivered with: 2 Rail Quick C 128 Red, 1 Bike-Block Pro 1 and 3 Red. 02093B38-

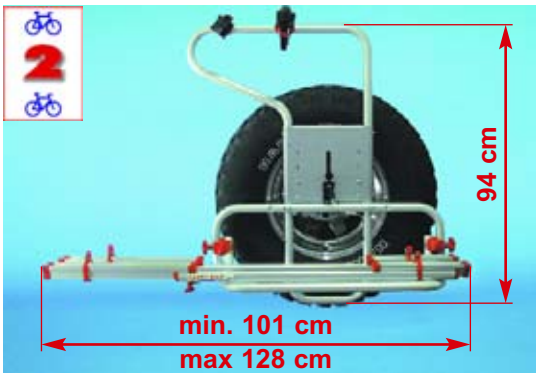
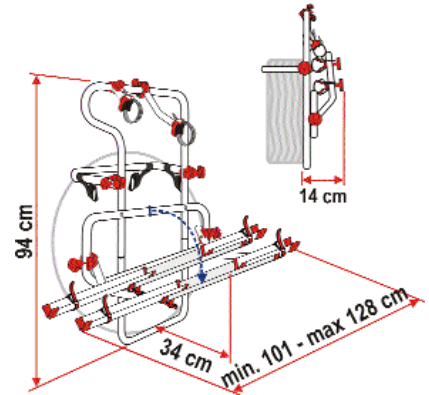

4x4



ADAPTER 4x4

Allows you to adapt the Carry-Bike 4x4 to various sport utility vehicles: - **Universal (standard delivered)** for Opel Frontera Sport, Toyota Land-Cruiser, Suzuki without antitheft device, Mitsubishi Pajero, Daihatsu and Nissan Terrano 1. Adjustable bracket min. 100 mm max 150 mm.

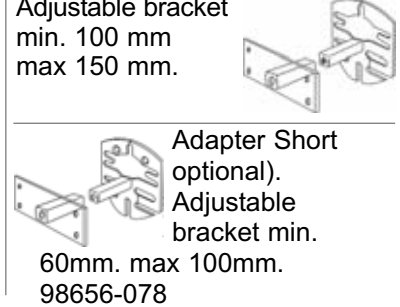
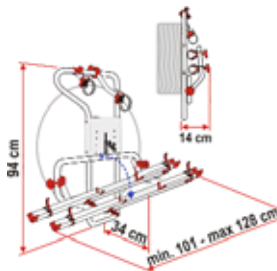

Specially designed for 4-wheel drive vehicles. It is installed onto the rear spare tyre and carries 2 bikes. The structure can be assembled on either the right or left side where the spare tyre is located. The support rails fold up when not in use. Installation wrench included. 02093N01-

BACKPACK



**The carry-bike with universal straps is easily installed on all minivans. Pay attention so it doesn't cover the lights and the number plate.
Not adapted to rear doors made of fibreglass.**

No tools are required for the installation, 6 superior Heavy Duty Quick Lock straps secure the bike carrier to the vehicle. Sturdy anodized aluminium tubes. Inox steel screws. Standard delivered with: 2 telescopic Quick strip rails, Bike-Block Pro 1 and 3. Carries 2 bikes, but with the option to fit a 3rd rail. Carries up to 50kg. 02093A38-



CARRY-BIKE