



Designed for vans with double rear doors

**VAN**



## 200 DJ

Bike carrier for vans with double rear doors. It is not necessary to drill holes in the vehicle, except for the security screws. The rear door can be opened without removing the bicycles. Can be combined with the Deluxe 6 DJ ladder (page 64). Standard delivered with 2 Rail Strip C Red, 1 Bike-Block Pro 1 and 2 Red, 1 Rack Holder, installation bracket and Fixing-Bar.

02093-65-

**The CB 200 DJ can be installed on the following vehicles:**

Fiat Ducato after 2000  
Peugeot Boxer after 2000  
Citroën Jumper after 2000  
Mercedes Sprinter



**Warning:** the Carry-Bike 200 DJ has to be installed on the right side and the ladder on the left side of the rear doors.



## 200 D

Bike carrier for vans with double rear doors, wheelbase variable from 58 to 62cm to adapt to different rear doors.

Upper wall installation steel brackets are only 34mm wide.

Standard delivered with:

2 Rail Strip C Red, 1 Bike-Block Pro 1 and 2 Red, 1 Rack Holder.

02093-15-

**The CB 200 D can be installed on the following vehicles**

Fiat Ducato before 1999  
Peugeot J5 before 1999  
Citroën C25 before 1999  
Ford Transit  
VW LT

VW LT high roof  
Mercedes MB 100  
Ford Transit high roof  
Citroën Jumper  
Peugeot Boxer

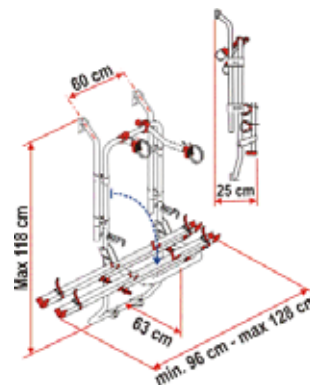

CARRY-BIKE®



## RENAULT TRAFIC D

Bike carrier suitable for Renault Traffic D and Opel Vivaro with double rear doors. It is easily installed with brackets without having to drill holes in the vehicle. Standard delivered with 2 Rail Strip C Red, 1 Bike-Block Pro 1 and 2 Red.

**DS version for standard roof:**

02093-74-

**DL version for high roof:**

02093-73-

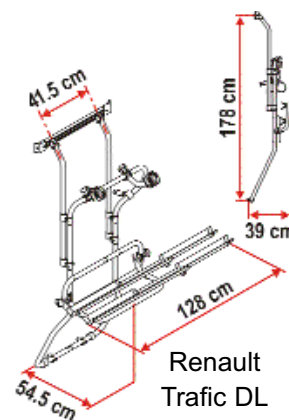

Renault Traffic DL

Carry-Bike Traffic DL

Carry-Bike Traffic DS